

DWG NO. -

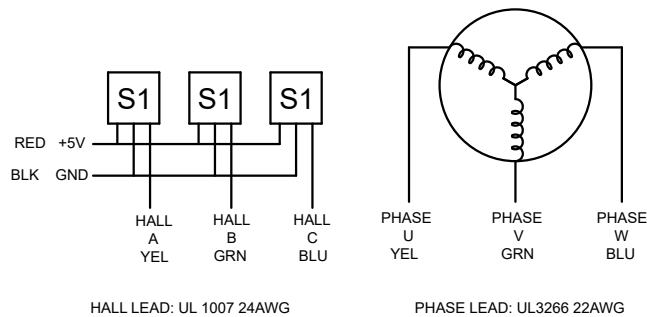

SPECIFICATION	VALUE
NO. of PHASES	3
NO. of POLES	8
RESISTANCE/PHASE(Ohms)@25°C	3.70±10%
INDUCTANCE/PHASE(mH)@1KHz	3.70±20%
RATED VOLTAGE(V)	24
RATED TORQUE(N.m)[lb-in]	0.063[0.56]
RATED POWER(W)	20
RATED SPEED(RPM)	3000±10%
RATED CURRENT(A)	1.20
NO LOAD SPEED(RPM)	4100±10%
WEIGHT(kg)	—
BACK EMF(V/krpm)	4.00±5%
SENSOR	HALL
AMBIENT TEMPERATURE	-10°C~50°C[14°F~122°F]
INSULATION CLASS	B 130°C[266°F]
TEMPERATURE RISE	MAX.80°C

UNIT mm  
 GB/T 1804-M EQV.ISO 2768-1 CLASS M:  
 ≤6 ±0.1  
 >6~30 ±0.2  
 >30~120 ±0.3  
 >120~400 ±0.5

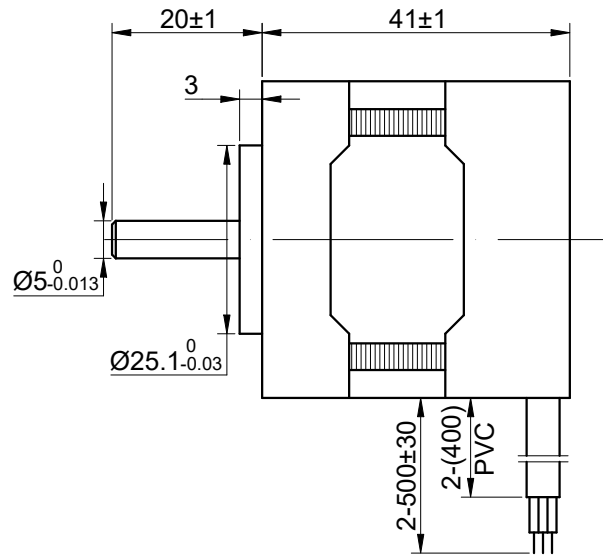
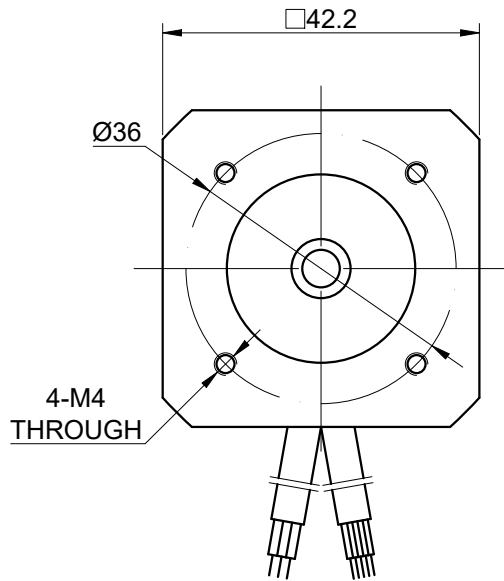
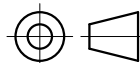

mm

UNITS

3:2

SCALE

DRN

APVD

SIGNATURE

MYX

LDJ

DATE

1.15.2026

1.15.2026

DATE

**BRUSHLESS DC MOTOR**

**42BSB41-24-01**

**OSMTEC**®  
 Stepper Motor Specialists