

DWG NO. -

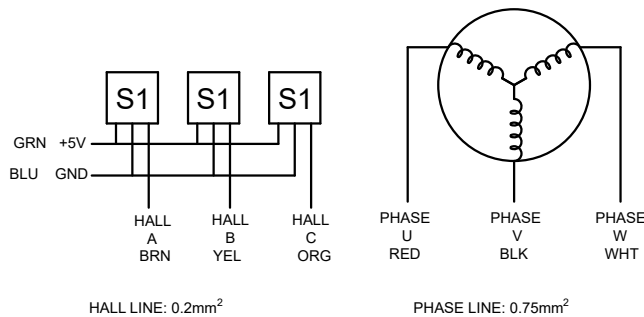
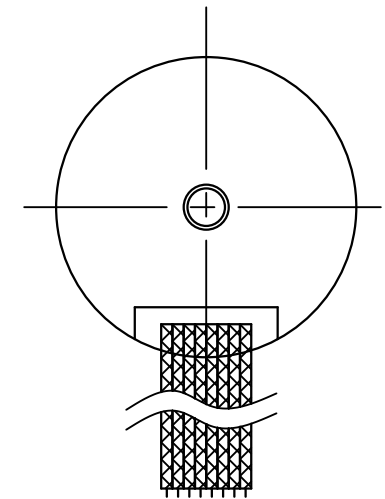
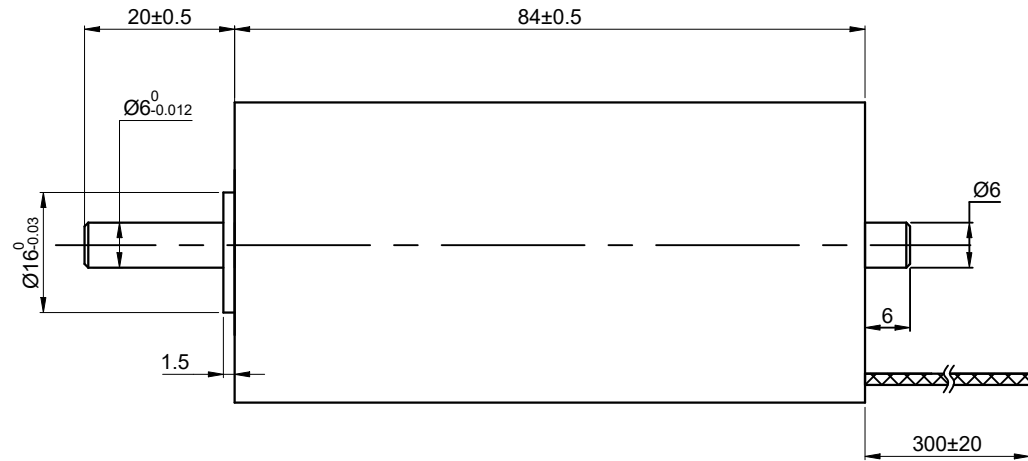
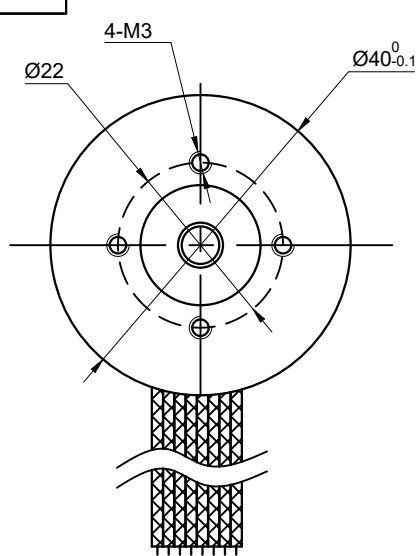

SPECIFICATION	VALUE
RATED VOLTAGE(V)	24
TERMINAL RESISTANCE(Ohms)	0.24
TERMINAL INDUCTANCE(mH)	0.07
NO LOAD SPEED(RPM)	11000
NO LOAD CURRENT(A)	0.55
RATED SPEED(RPM)	9200
RATED CURRENT(A)	9.65
RATED TORQUE(mNm)	200
RATED POWER(W)	192.67
THE GREATEST POWER OUTPUT(W)	593.42
EFFICIENCY(%)	85.72
TORQUE CONSTANT(mNm/A)	20.72
STALL TORQUE (mNm)	2060.63
BACK-EMF CONSTANT(mV/RPM)	2.17
SPEED CONSTANT(RPM/V)	460.87
FRICITION TORQUE(mNm)	11.40
CURRENT CONSTANT(A/mNm)	0.05

UNIT mm  
 GB/T 1804-M EQV.ISO 2768-1 CLASS M:  
 ≤6 ±0.1  
 >6~30 ±0.2  
 >30~120 ±0.3  
 >120~400 ±0.5

**OSMTEC**®  
 Stepper Motor Specialists

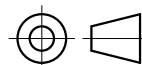

mm			
UNITS	DRN	MYX	1.13.2026
3:2	APVD	LDJ	1.13.2026
SCALE	SIGNATURE	DATE	

**BRUSHLESS DC MOTOR**

**40CL84-24-P2-9200**