

DWG NO. -

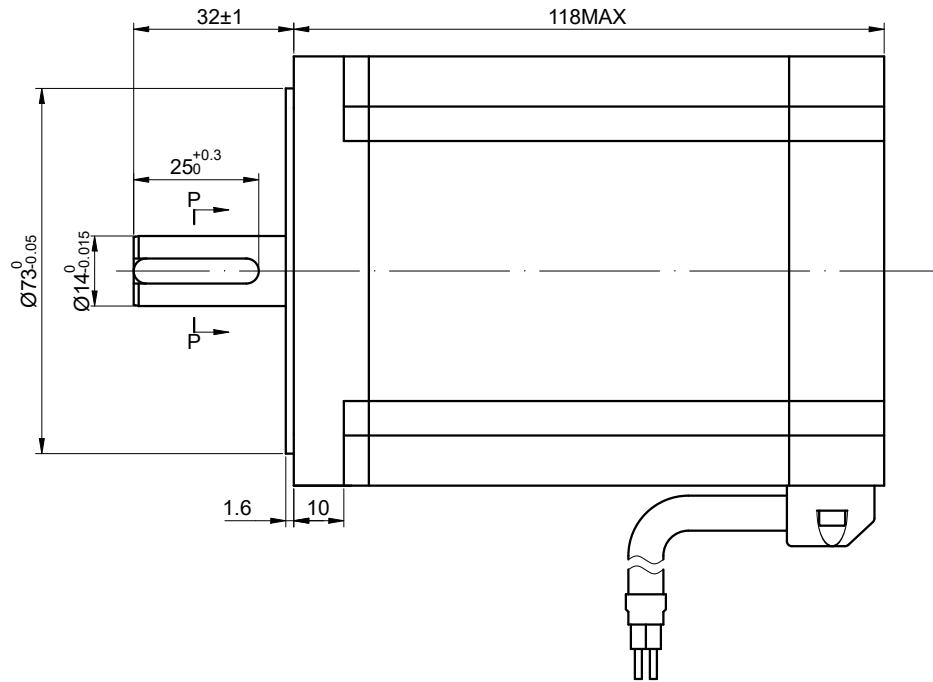
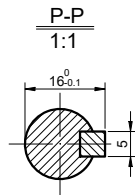
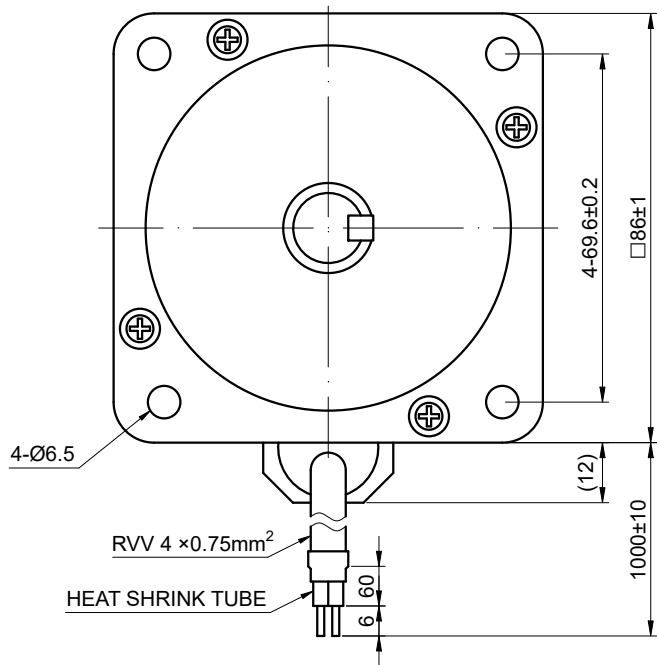

FULL STEP 2 PHASE-Ex., WHEN FACING MOUNTING END (X)

STEP	A+	B+	A-	B-		CCW
1	+	+	-	-	↓ ↑ CW	↑
2	-	+	+	-		
3	-	-	+	+		
4	+	-	-	+		

UNIT mm
GB/T 1804-M EQV.ISO
2768-1 CLASS M:
≤6 ±0.1
>6~30 ±0.2
>30~120 ±0.3
>120~400 ±0.5

WINDING			CONNECTION	BIPOLAR
			SPECIFICATION	
			AMPS/PHASE	6.00
			RESISTANCE/PHASE(Ohms)@25°C	0.58±10%
			INDUCTANCE/PHASE(mH)@1KHz	5.00±20%
			HOLDING TORQUE(Nm)[lb-in]	8.50[75.29]
			STEP ANGLE(°)	1.80
PIN NO	BIPOLAR	LEADS	ROTOR INERTIA(g·cm²)	2700
1	A+	BLK	WEIGHT(Kg)[lb]	3.6
2	A-	GRN	AMBIENT TEMPERATURE	-10°C~50°C[14°F~122°F]
3	B+	RED	INSULATION CLASS	B 130°C[266°F]
4	B-	BLU	TEMPERATURE RISE	MAX.80°C

OSMTEC®
Stepper Motor Specialists

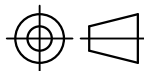

mm

UNITS

2:3

SCALE

DRN

APVD

SIGNATURE

YSX

LJ

DATE

1.13.2026

1.13.2026

STEPPER MOTOR

34HS46-6004S1