

DWG NO. -

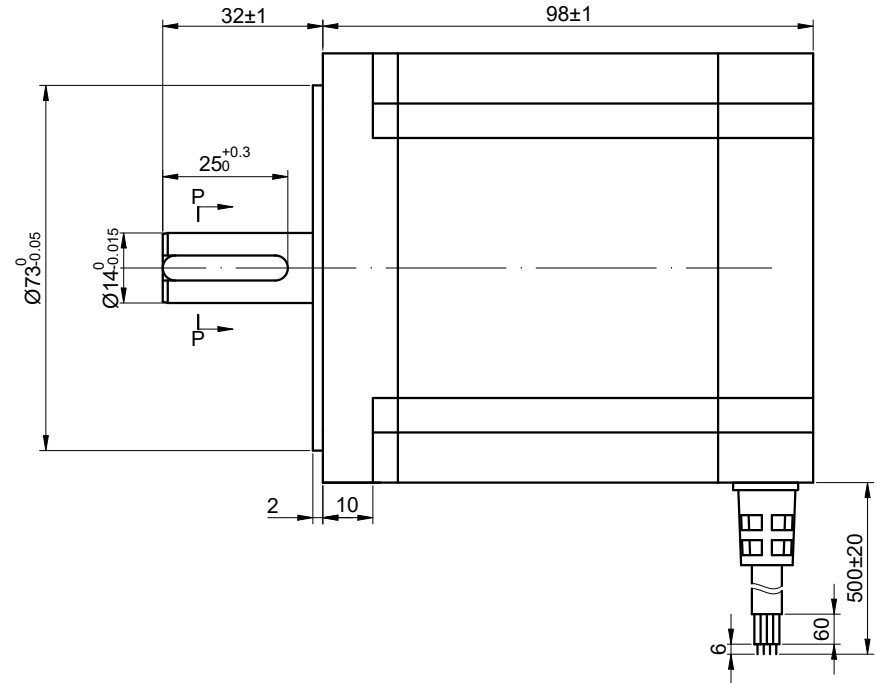
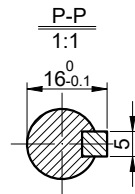
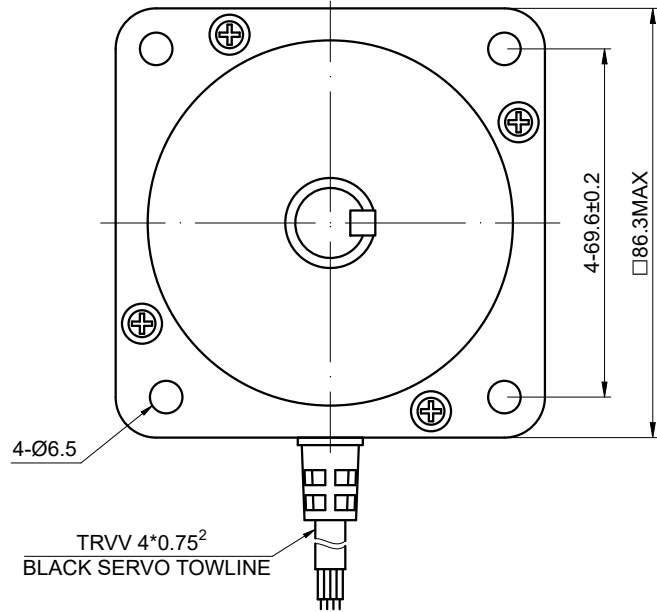

FULL STEP 2 PHASE-Ex., WHEN FACING MOUNTING END (X)

STEP	A+	B+	A-	B-		CCW
1	+	+	-	-		
2	-	+	+	-		
3	-	-	+	+		
4	+	-	-	+		

UNIT mm
 GB/T 1804-M EQV.ISO
 2768-1 CLASS M:
 <=6 ±0.1
 >6~30 ±0.2
 >30~120 ±0.3
 >120~400 ±0.5

WINDING			CONNECTION		BIPOLAR
			SPECIFICATION		
			AMPS/PHASE		6.00
			RESISTANCE/PHASE(Ohms)@25°C		0.55±10%
			INDUCTANCE/PHASE(mH)@1KHz		4.60±20%
			HOLDING TORQUE(Nm)[lb-in]		8.00[70.81]
			STEP ANGLE(°)		1.80
STEP ACCURACY(NON-ACCUM)		±5.00%	ROTOR INERTIA(g-cm²)		—
PIN NO	BIPOLAR	LEADS	WEIGHT(Kg)[lb]		—
1	A+	BLK	AMBIENT TEMPERATURE		-10°C~50°C[14°F~122°F]
2	A-	GRN	INSULATION CLASS		B 130°C[266°F]
3	B+	RED	TEMPERATURE RISE		MAX.80°C
4	B-	BLU			

OSMTEC®
 Stepper Motor Specialists

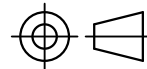

mm

UNITS

2:3

SCALE

DRN

APVD

SIGNATURE

YSX

LJ

DATE

1.13.2026

1.13.2026

STEPPER MOTOR

34HS39-6004S