

4-PIN GX16 FEMALE PLUG 15-PIN DB MALE PLUG

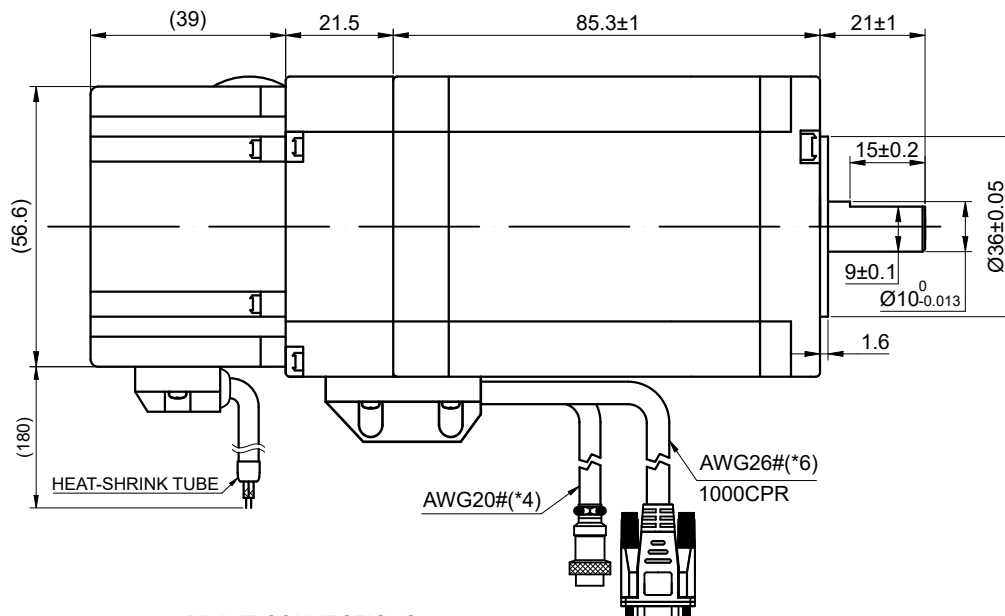

BRAKE CONNECTIONS

24V 2.0N.m

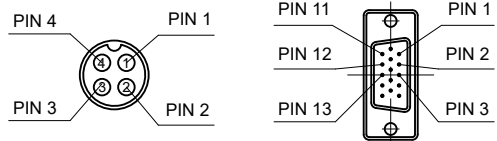
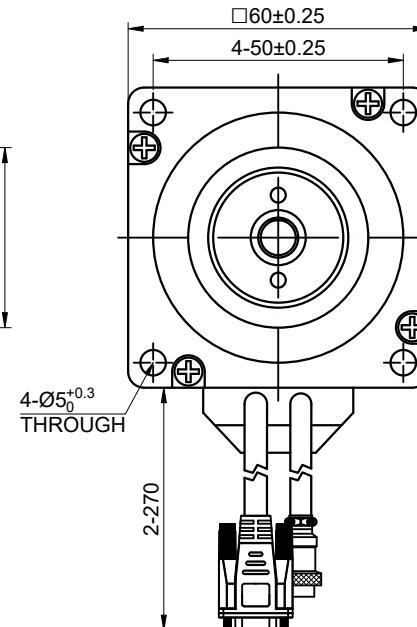
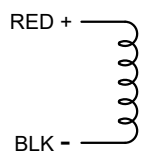

15-PIN DB MALE PLUG	1	2	3	11	12	13
DESCRIPTION	EA+	VCC	GND	EB+	EB-	EA-

FULL STEP 2 PHASE-Ex., WHEN FACING MOUNTING END (X)

STEP	A+	B+	A-	B-		CCW
1	+	+	-	-	↓ CW	↑ CCW
2	-	+	+	-		
3	-	-	+	+		
4	+	-	-	+		

UNIT mm
GB/T 1804-M EQV.ISO
2768-1 CLASS M:
<=6 ±0.1
>6~30 ±0.2
>30~120 ±0.3
>120~400 ±0.5

WINDING			CONNECTION	
			SPECIFICATION	BIPOLAR
			AMPS/PHASE	5.00
			RESISTANCE/PHASE(Ohms)@25°C	0.45±10%
			INDUCTANCE/PHASE(mH)@1KHz	1.80±20%
			HOLDING TORQUE(Nm)[lb-in]	3.00 [26.57]
			STEP ANGLE(°)	1.80
			STEP ACCURACY(NON-ACCUM)	±5.00%
PIN NO	BIPOLAR	LEADS	ROTOR INERTIA(g-cm ²)	690
1	A+	--	WEIGHT(Kg)[lb]	—
2	A-	--	AMBIENT TEMPERATURE	-10°C~50°C[14°F~122°F]
3	B+	--	INSULATION CLASS	B 130°C[266°F]
4	B-	--	TEMPERATURE RISE	MAX.80°C

OSMTEC®
Stepper Motor Specialists

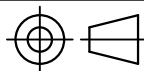

mm

UNITS

2:3

SCALE

DRN

APVD

SIGNATURE

ZPJ

YSX

DATE

1.16.2026

1.16.2026

DATE

STEPPER MOTOR

24E1KBK20-30