

DWG NO. -

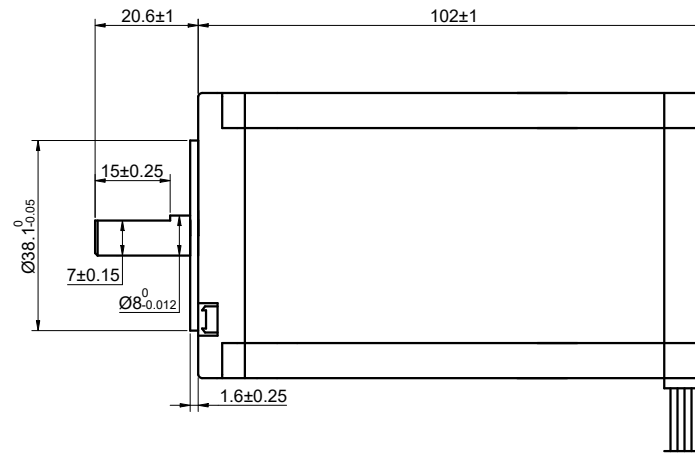
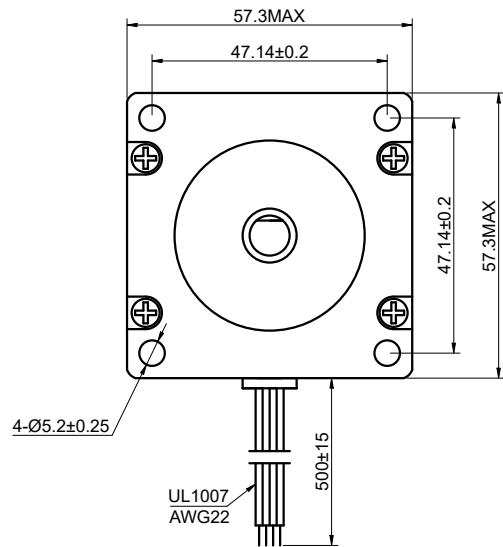

FULL STEP 2 PHASE-Ex., WHEN FACING MOUNTING END (X)

STEP	A+	B+	A-	B-		CCW
1	+	+	-	-	 CW	 CCW
2	-	+	+	-		
3	-	-	+	+		
4	+	-	-	+		

UNIT mm
 GB/T 1804-M EQV.ISO
 2768-1 CLASS M:
 <=6 ±0.1
 >6~30 ±0.2
 >30~120 ±0.3
 >120~400 ±0.5

WINDING			CONNECTION	BIPOLAR
			SPECIFICATION	
			AMPS/PHASE	1.80
			RESISTANCE/PHASE(Ohms)@25°C	2.55±10%
			INDUCTANCE/PHASE(mH)@1KHz	12.00±20%
			HOLDING TORQUE(Nm)[lb-in]	2.40[21.24]
			STEP ANGLE(°)	1.80
PIN NO	BIPOLAR	LEADS	ROTOR INERTIA(g-cm ²)	680.00
1	A+	BLK	WEIGHT(Kg)[lb]	—
2	A-	GRN	AMBIENT TEMPERATURE	-10°C~50°C[14°F~122°F]
3	B+	RED	INSULATION CLASS	B 130°C[266°F]
4	B-	BLU	TEMPERATURE RISE	MAX.80°C

OSMTEC®
 Stepper Motor Specialists

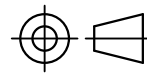

mm			
UNITS	DRN	YSX	1.13.2026
2:3	APVD	LJ	1.13.2026
SCALE	SIGNATURE	DATE	

STEPPER MOTOR
 23HS41-1804S