

DWG NO. -

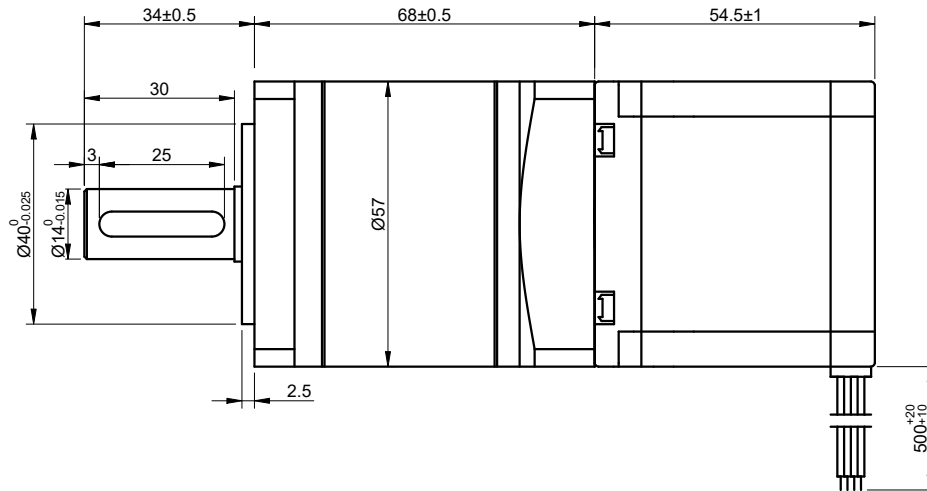
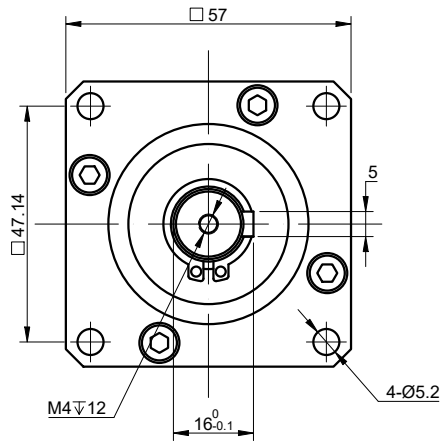

SPECIFICATION	VALUE
AMPS/PHASE	2.90
RESISTANCE/PHASE(Ohms)@25°C	0.90±10%
INDUCTANCE/PHASE(mH)@1KHz	2.60±20%
HOLDING TORQUE w/o GEARBOX(Nm)[lb-in]	1.20[10.63]
GEAR RATIO	50
EFFICIENCY	80%
STEP ANGLE w/o GEARBOX(°)	1.80
BACKLASH@NO-LOAD	<=45arcmin
MAX.PERMISSIBLE TORQUE(Nm)	20.00
MOMENT PERMISSIBLE TORQUE(Nm)	40.00
SHAFT MAXIMUM AXIAL LOAD(N)	200
SHAFT MAXIMUM RADIAL LOAD(N)	400
AMBIENT TEMPERATURE	-10°C~50°C[14°F~122°F]
INSULATION CLASS	B 130°C[266°F]
TEMPERATURE RISE	MAX.80°C

FULL STEP 2 PHASE-Ex.,WHEN FACING MOUNTING END (X)

STEP	A+	B+	A-	B-	CW	CCW
1	+	+	-	-	 	
2	-	+	+	-		
3	-	-	+	+		
4	+	-	-	+		

UNIT mm
GB/T 1804-M EQV.ISO
2768-1 CLASS M:
<=6 ±0.1
>6~30 ±0.2
>30~120 ±0.3
>120~400 ±0.5

MOTOR CONNECTION

PIN NO	BIPOLAR	LEADS
1	A+	--
2	A-	--
3	B+	--
4	B-	--

OSMTEC®
Stepper Motor Specialists

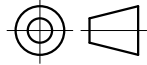

mm			
UNITS	DRN	ZPJ	1.13.2026
2:3	APVD	YSX	1.13.2026
SCALE	SIGNATURE	DATE	

GEARBOX MOTOR

23HS22-2904S-MG50