

DWG NO. -

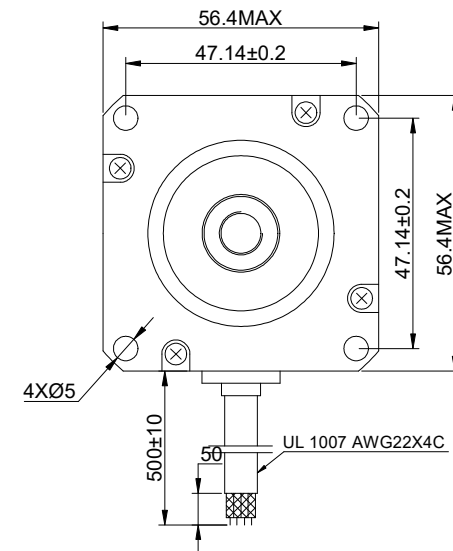
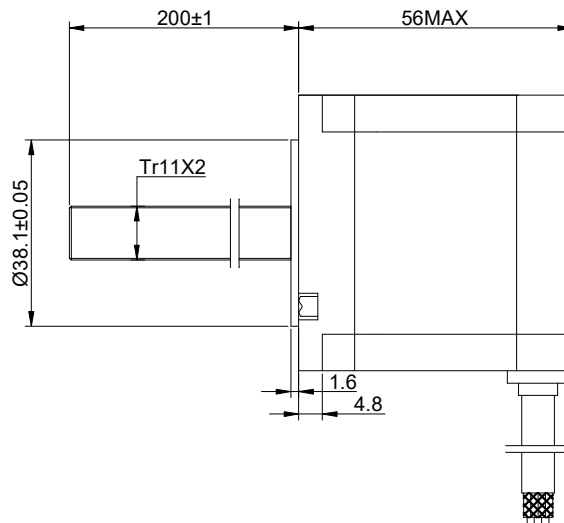
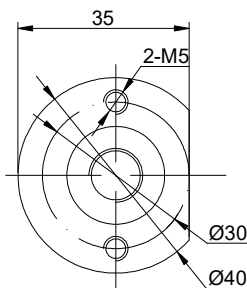
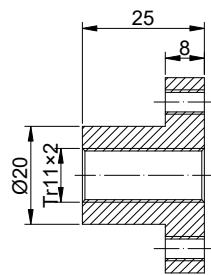

FULL STEP 2 PHASE-Ex.,WHEN FACING MOUNTING END (X)

STEP	A+	B+	A-	B-	CW ↓	CCW ↑
1	+	+	-	-		
2	-	+	+	-		
3	-	-	+	+		
4	+	-	-	+		

UNIT mm
GB/T 1804-M EQV.ISO
2768-1 CLASS M:
<=6 ±0.1
>6~30 ±0.2
>30~120 ±0.3
>120~400 ±0.5

OSMTEC[®]
Stepper Motor Specialists

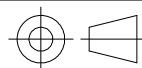

mm

UNITS

2:3

SCALE

WINDING			CONNECTION		SPECIFICATION		BIPOLAR	
			AMPS/PHASE		2.00		2.00	
			RESISTANCE/PHASE(Ohms)@25°C		3.60±10%		3.60±10%	
			INDUCTANCE/PHASE(mH)@1KHz		12.00±20%		12.00±20%	
			HOLDING TORQUE(Nm)[lb-in]		1.20[10.62]		1.20[10.62]	
			STEP ANGLE(°)		1.80		1.80	
			STEP ACCURACY(NON-ACCUM)		±5.00%		±5.00%	
PIN NO	BIPOLAR	LEADS	LEAD(mm)		2			
1	A+	BLK	LINEAR TRAVEL/STEP(mm)		0.01			
2	A-	GRN	AMBIENT TEMPERATURE		-10°C~50°C[14°F~122°F]			
3	B+	RED	INSULATION CLASS		B 130°C[266°F]			
4	B-	BLU	TEMPERATURE RISE		MAX.80°C			
			LINEAR STEPPER MOTOR					
			23E22S2004AJ2-200RS					
DRN		LDJ	1.14.2026					
APVD		ZPJ	1.19.2026					
SIGNATURE		DATE						