

DWG NO. -

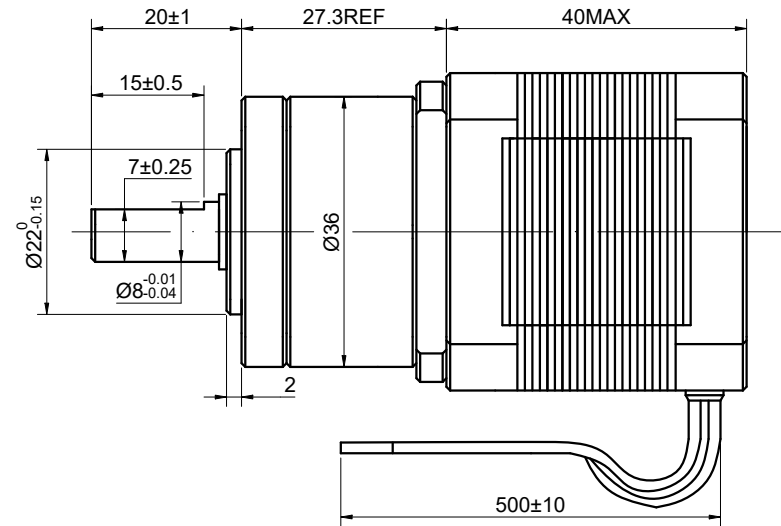
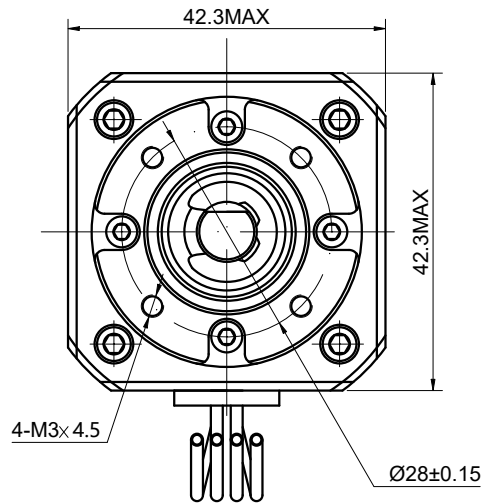

SPECIFICATION	VALUE
AMPS/PHASE	1.68
RESISTANCE/PHASE(Ohms)@25°C	1.60±10%
INDUCTANCE/PHASE(mH)@1KHz	3.10±20%
HOLDING TORQUE w/o GEARBOX(Nm)[lb-in]	0.39[3.45]
GEAR RATIO	5 ² / ₁₁
EFFICIENCY	90.00%
STEP ANGLE w/o GEARBOX(°)	1.80
BACKLASH@NO-LOAD	<=3°
MAX.PERMISSIBLE TORQUE(Nm)	3.00
MOMENT PERMISSIBLE TORQUE(Nm)	5.00
SHAFT MAXIMUM AXIAL LOAD(N)	50.00
SHAFT MAXIMUM RADIAL LOAD(N)	100.00
AMBIENT TEMPERATURE	-10°C~50°C[14°F~122°F]
INSULATION CLASS	B 130°C[266°F]
TEMPERATURE RISE	MAX.80°C

FULL STEP 2 PHASE-Ex.,WHEN FACING MOUNTING END (X)

STEP	A+	B+	A-	B-	CW	CCW
1	+	+	-	-	↓	↑
2	-	+	+	-	↓	↑
3	-	-	+	+	↓	↑
4	+	-	-	+	↓	↑

UNIT mm
GB/T 1804-M EQV.ISO
2768-1 CLASS M:
<=6 ±0.1
>6~30 ±0.2
>30~120 ±0.3
>120~400 ±0.5

MOTOR CONNECTION

PIN NO	BIPOLAR	LEADS	A+	A-	B+	B-
1	A+	BLK	⊕	⊖	⊕	⊖
2	A-	GRN	⊕	⊖	⊕	⊖
3	B+	RED	⊕	⊖	⊕	⊖
4	B-	BLU	⊕	⊖	⊕	⊖

OSMTEC®
Stepper Motor Specialists

mm			
UNITS	DRN	YSX	1.13.2026
1:1	APVD	LJ	1.13.2026
SCALE	SIGNATURE	DATE	

GEARBOX MOTOR
17HS15-1684S-PG5