

DWG NO. -

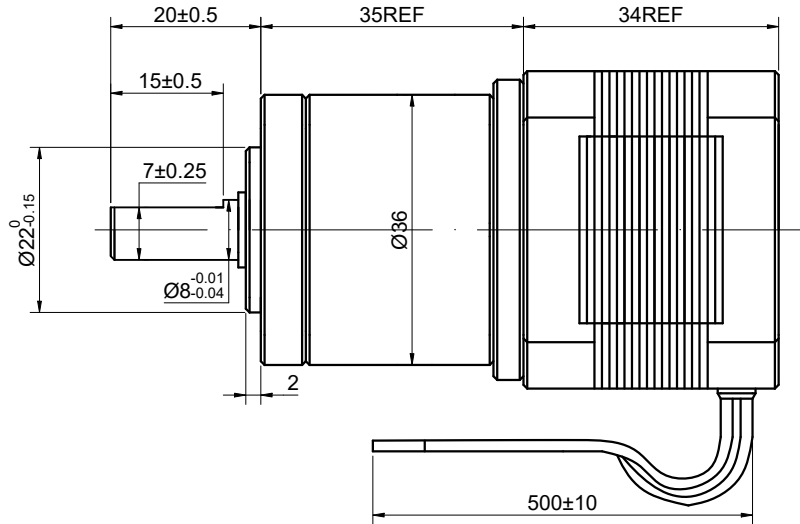
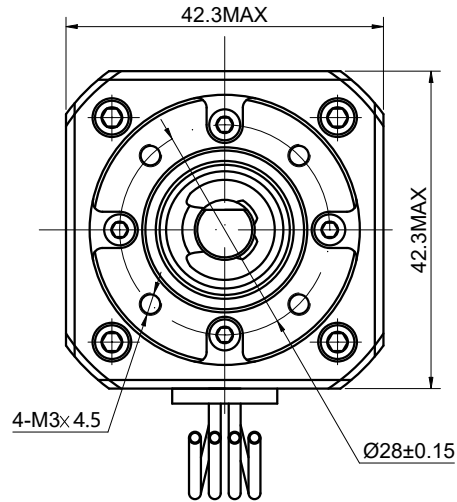

| SPECIFICATION | VALUE |
|---------------------------------------|------------------------------------|
| AMPS/PHASE | 0.4 |
| RESISTANCE/PHASE(Ohms)@25°C | 27.00±10% |
| INDUCTANCE/PHASE(mH)@1KHz | 28.50±20% |
| HOLDING TORQUE w/o GEARBOX(Nm)[lb-in] | 0.25[2.21] |
| GEAR RATIO | 26 ¹⁰³ / ₁₂₁ |
| EFFICIENCY | 80.00% |
| STEP ANGLE w/o GEARBOX(°) | 1.80 |
| BACKLASH@NO-LOAD | <=3° |
| MAX.PERMISSIBLE TORQUE(Nm) | 3.00 |
| MOMENT PERMISSIBLE TORQUE(Nm) | 5.00 |
| SHAFT MAXIMUM AXIAL LOAD(N) | 50.00 |
| SHAFT MAXIMUM RADIAL LOAD(N) | 100.00 |
| AMBIENT TEMPERATURE | -10°C~50°C[14°F~122°F] |
| INSULATION CLASS | B 130°C[266°F] |
| TEMPERATURE RISE | MAX.80°C |

FULL STEP 2 PHASE-Ex.,WHEN FACING MOUNTING END (X)

| STEP | A+ | B+ | A- | B- | CW | CCW |
|------|----|----|----|----|----|-----|
| 1 | + | + | - | - | ↓ | ↑ |
| 2 | - | + | + | - | ↓ | ↑ |
| 3 | - | - | + | + | ↓ | ↑ |
| 4 | + | - | - | + | ↓ | ↑ |

UNIT mm
GB/T 1804-M EQV.ISO
2768-1 CLASS M:
<=6 ±0.1
>6~30 ±0.2
>30~120 ±0.3
>120~400 ±0.5

MOTOR CONNECTION

| PIN NO | BIPOLAR | LEADS |
|--------|---------|-------|
| 1 | A+ | BLK |
| 2 | A- | GRN |
| 3 | B+ | RED |
| 4 | B- | BLU |

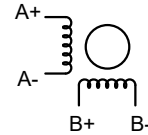

OSMTEC[®]
Stepper Motor Specialists

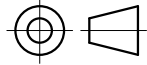

| mm | | | |
|-------|-----------|------|-----------|
| UNITS | DRN | YSX | 1.13.2026 |
| 1:1 | APVD | LJ | 1.13.2026 |
| SCALE | SIGNATURE | DATE | |

GEARBOX MOTOR

17HS13-0404S-PG27