

DWG NO. -

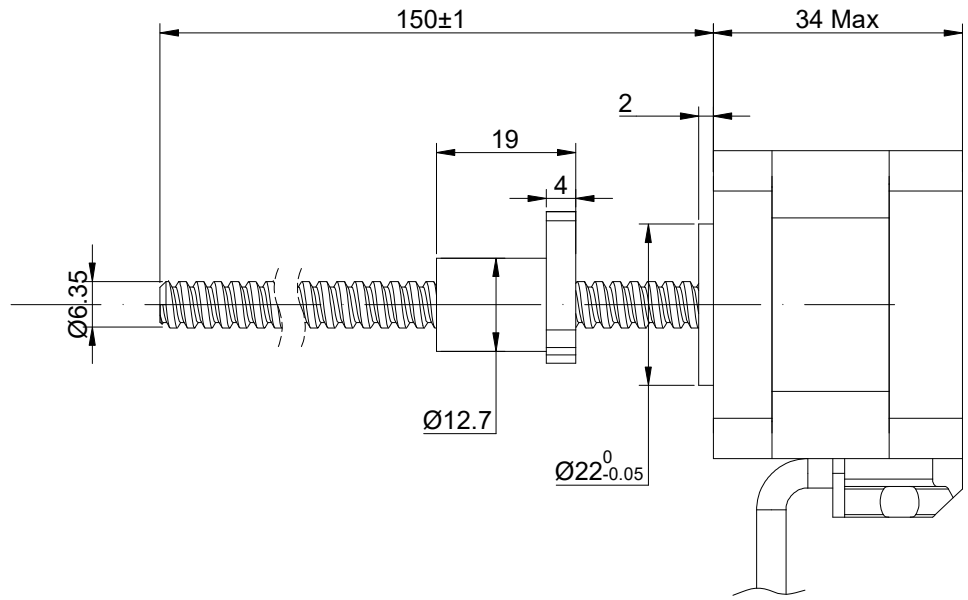
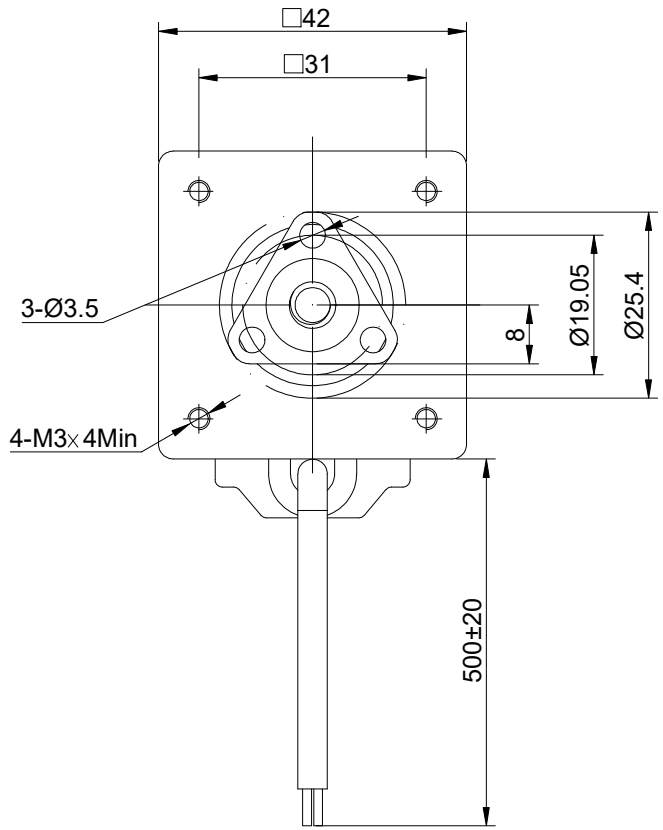

FULL STEP 2 PHASE-Ex.,WHEN FACING MOUNTING END (X)

STEP	A+	B+	A-	B-	↓ CW	↑ CCW
1	+	+	-	-		
2	-	+	+	-		
3	-	-	+	+		
4	+	-	-	+		

UNIT mm
 GB/T 1804-M EQV.ISO
 2768-1 CLASS M:
 <=6 ±0.1
 >6~30 ±0.2
 >30~120 ±0.3
 >120~400 ±0.5

WINDING			CONNECTION		BIPOLAR
			SPECIFICATION		
			AMPS/PHASE		1.50
			RESISTANCE/PHASE(Ohms)@25°C		1.70±10%
			INDUCTANCE/PHASE(mH)@1KHz		2.50±20%
			HOLDING TORQUE(Nm)[lb-in]		0.25[2.21]
			STEP ANGLE(°)		1.80
STEP ACCURACY(NON-ACCUM)		±5.00%			
PIN NO	BIPOLAR	LEADS	LEAD(mm)		2.54
1	A+	RED	LINEAR TRAVEL/STEP(mm)		0.0127
2	A-	RED/WHT	AMBIENT TEMPERATURE		-10°C~50°C[14°F~122°F]
3	B+	GRN	INSULATION CLASS		B 130°C[266°F]
4	B-	GRN/WHT	TEMPERATURE RISE		MAX.80°C

OSMTEC[®]
 Stepper Motor Specialists

mm			
UNITS	DRN	LDJ	1.14.2026
1:1	APVD	ZPJ	1.20.2026
SCALE	SIGNATURE		DATE

LINEAR STEPPER MOTOR
 17E13S1504GF5-150RS