

DWG NO. -

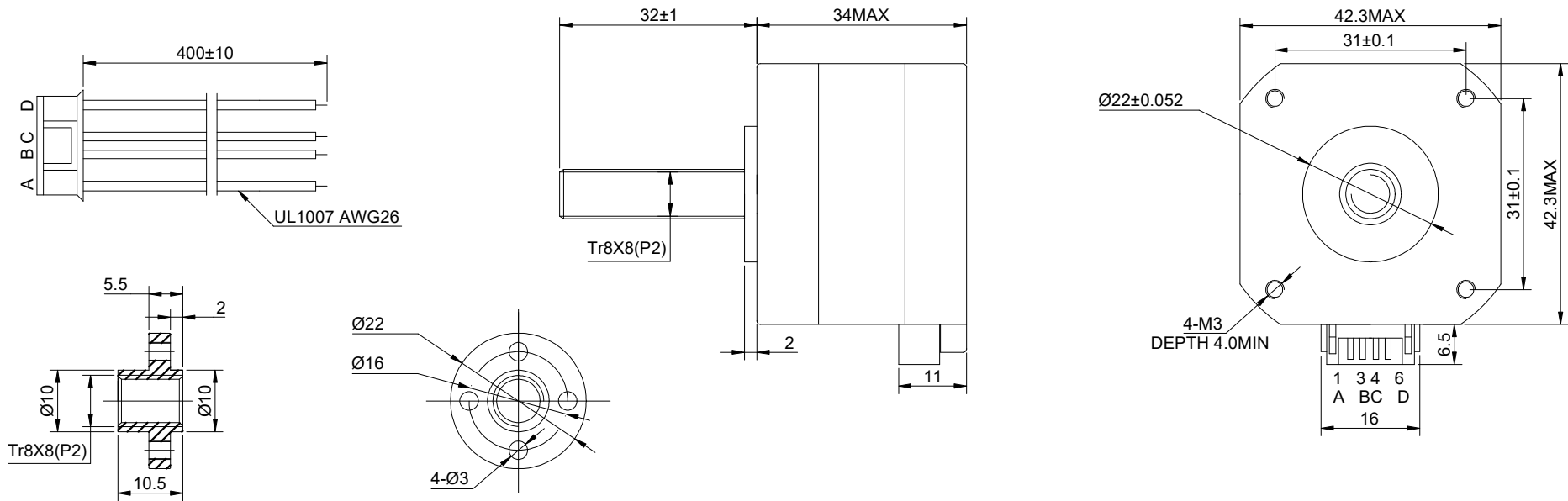

FULL STEP 2 PHASE-Ex.,WHEN FACING MOUNTING END (X)

STEP	A+	B+	A-	B-		CCW
1	+	+	-	-	↓ ↑ CW	↑
2	-	+	+	-		
3	-	-	+	+		
4	+	-	-	+		

UNIT mm
GB/T 1804-M EQV.ISO
2768-1 CLASS M:
<=6 ±0.1
>6~30 ±0.2
>30~120 ±0.3
>120~400 ±0.5

OSMTEC[®]
Stepper Motor Specialists

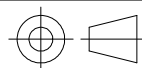

mm

UNITS

1:1

SCALE

WINDING			CONNECTION		BIPOLAR
			SPECIFICATION		
			AMPS/PHASE		0.40
			RESISTANCE/PHASE(Ohms)@25°C		30.00±10%
			INDUCTANCE/PHASE(mH)@1KHz		37.00±20%
			HOLDING TORQUE(Nm)[lb-in]		0.26[2.30]
			STEP ANGLE(°)		1.80
STEP ACCURACY(NON-ACCUM)		±5.00%			
PIN NO	BIPOLAR	LEADS	LEAD(mm)		8
1	A+	RED	LINEAR TRAVEL/STEP(mm)		0.04
2	A-	GRY	AMBIENT TEMPERATURE		-10°C~50°C[14°F~122°F]
3	B+	YEL	INSULATION CLASS		B 130°C[266°F]
4	B-	GRN	TEMPERATURE RISE		MAX.80°C

LINEAR STEPPER MOTOR

17E13S0404MB2-032RB

DRN LDJ 1.16.2026

APVD ZPJ 1.20.2026

SIGNATURE DATE