

DWG NO. -

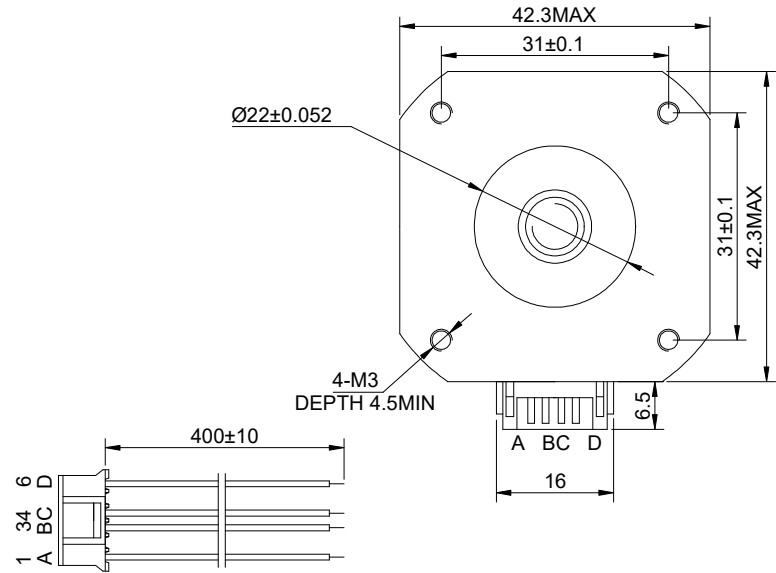
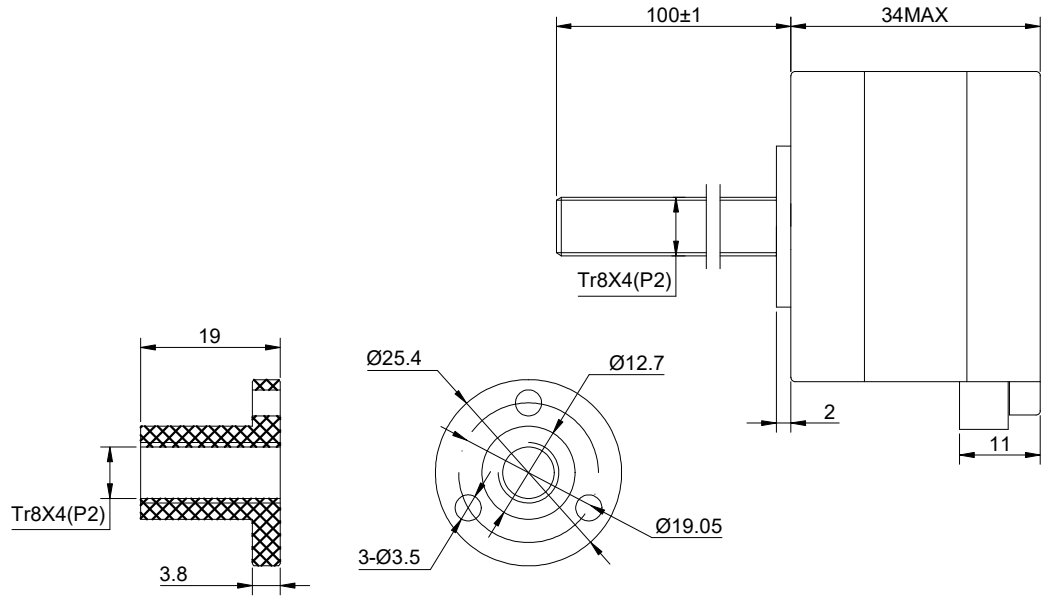

FULL STEP 2 PHASE-Ex.,WHEN FACING MOUNTING END (X)

STEP	A+	B+	A-	B-		CCW
1	+	+	-	-	↓ ↑ CW	↑
2	-	+	+	-		
3	-	-	+	+		
4	+	-	-	+		

UNIT mm
GB/T 1804-M EQV.ISO
2768-1 CLASS M:
<=6 ±0.1
>6~30 ±0.2
>30~120 ±0.3
>120~400 ±0.5

OSMTEC[®]
Stepper Motor Specialists

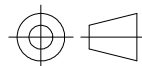

mm			
UNITS	DRN	LDJ	1.16.2026
1:1	APVD	ZPJ	1.20.2026
SCALE	SIGNATURE		DATE

WINDING			CONNECTION	
			SPECIFICATION	BIPOLAR
			AMPS/PHASE	0.40
			RESISTANCE/PHASE(Ohms)@25°C	30.00±10%
			INDUCTANCE/PHASE(mH)@1KHz	37.00±20%
			HOLDING TORQUE(Nm)[lb-in]	0.26[2.30]
			STEP ANGLE(°)	1.80
STEP ACCURACY(NON-ACCUM)	±5.00%			
PIN NO	BIPOLAR	LEADS	LEAD(mm)	
1	A+	RED	LINEAR TRAVEL/STEP(mm)	0.02
2	A-	GRY	AMBIENT TEMPERATURE	-10°C~50°C[14°F~122°F]
3	B+	YEL	INSULATION CLASS	B 130°C[266°F]
4	B-	GRN	TEMPERATURE RISE	MAX.80°C

LINEAR STEPPER MOTOR

17E13S0404DB4-100RS