

DWG NO. -

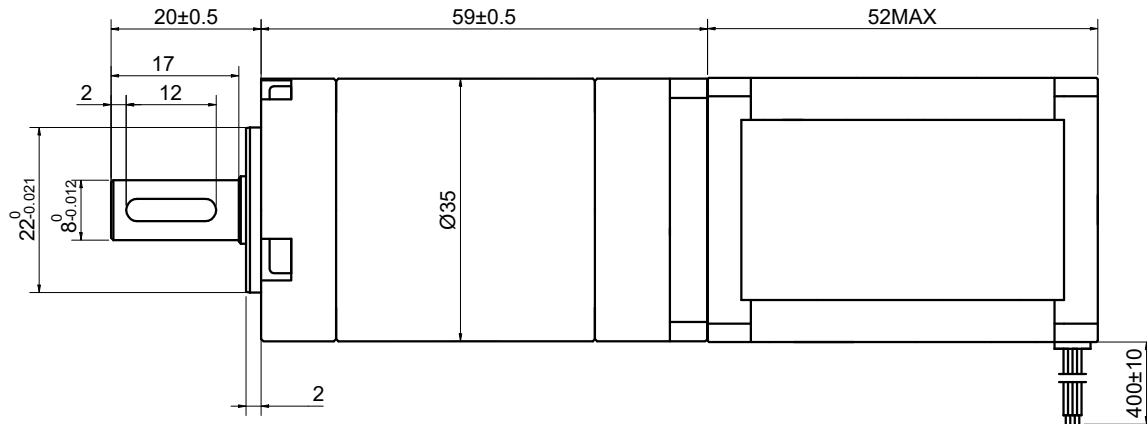
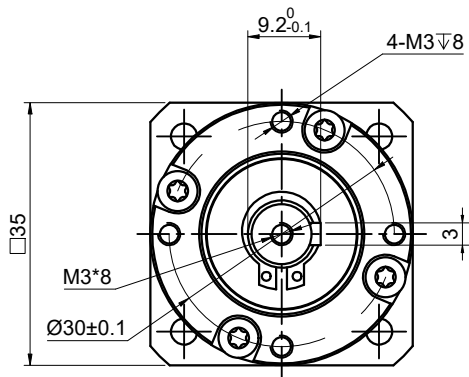

SPECIFICATION	VALUE
AMPS/PHASE	1.50
RESISTANCE/PHASE(Ohms)@25°C	2.80±10%
INDUCTANCE/PHASE(mH)@1KHz	4.80±20%
HOLDING TORQUE w/o GEARBOX(Nm)[lb-in]	0.4[3.53]
GEAR RATIO	100
EFFICIENCY	90%
STEP ANGLE w/o GEARBOX(°)	1.80
BACKLASH@NO-LOAD	<=25arcmin
MAX.PERMISSIBLE TORQUE(Nm)	9.00
MOMENT PERMISSIBLE TORQUE(Nm)	18.00
SHAFT MAXIMUM AXIAL LOAD(N)	100
SHAFT MAXIMUM RADIAL LOAD(N)	300
AMBIENT TEMPERATURE	-10°C~50°C[14°F~122°F]
INSULATION CLASS	B 130°C[266°F]
TEMPERATURE RISE	MAX.80°C

FULL STEP 2 PHASE-Ex.,WHEN FACING MOUNTING END (X)

STEP	A+	B+	A-	B-	CW
1	+	+	-	-	
2	-	+	+	-	
3	-	-	+	+	
4	+	-	-	+	

UNIT mm
GB/T 1804-M EQV.ISO
2768-1 CLASS M:
<=6 ±0.1
>6~30 ±0.2
>30~120 ±0.3
>120~400 ±0.5

MOTOR CONNECTION

PIN NO	BIPOLAR	LEADS
1	A+	BLK
2	A-	GRN
3	B+	RED
4	B-	BLU

OSMTEC®
Stepper Motor Specialists

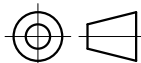

mm			
UNITS	DRN	ZPJ	1.13.2026
1:1	APVD	YSX	1.13.2026
SCALE	SIGNATURE	DATE	

GEARBOX MOTOR
14HS20-1504S-EGS100