

DWG NO. -

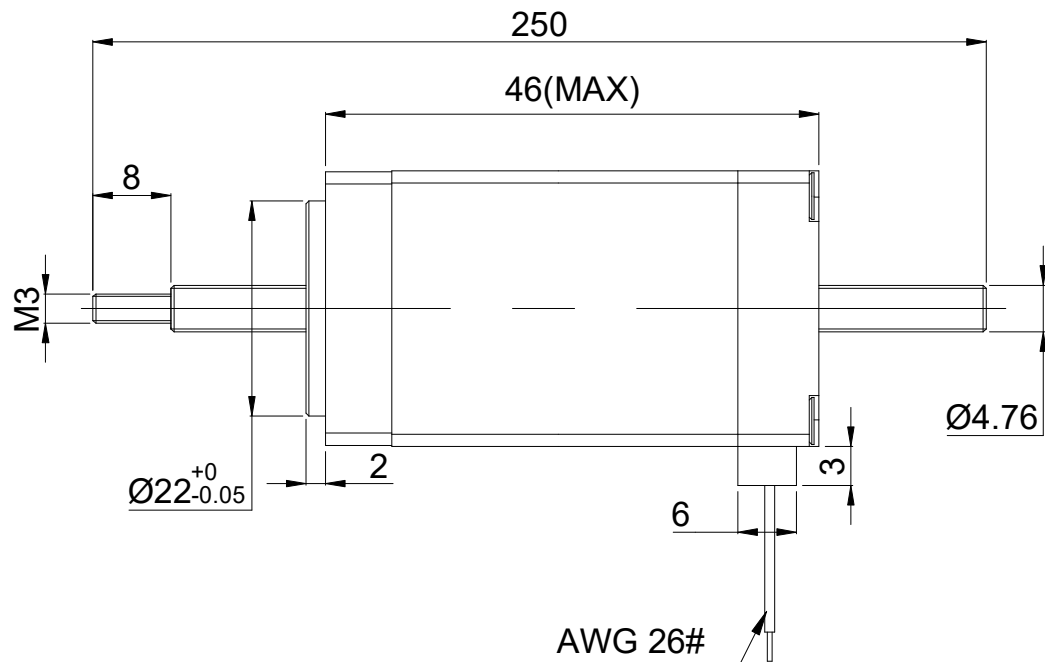
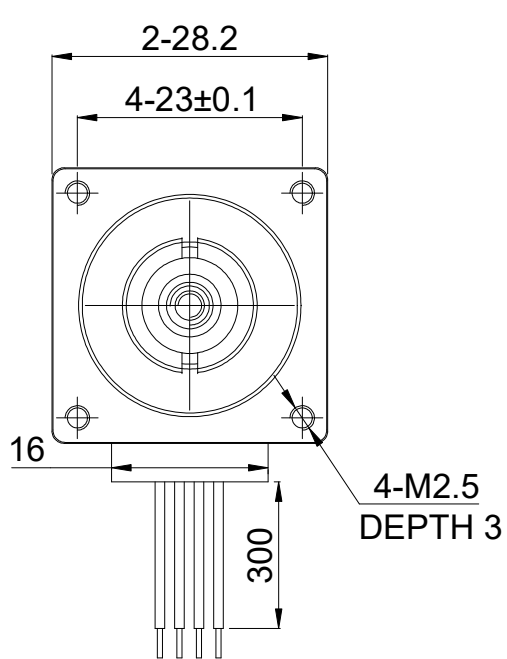

FULL STEP 2 PHASE-Ex.,WHEN FACING MOUNTING END (X)

STEP	A+	B+	A-	B-		CCW
1	+	+	-	-	 	
2	-	+	+	-		
3	-	-	+	+		
4	+	-	-	+		

UNIT mm  
GB/T 1804-M EQV.ISO  
2768-1 CLASS M:  
<=6 ±0.1  
>6~30 ±0.2  
>30~120 ±0.3  
>120~400 ±0.5

WINDING			CONNECTION		BIPOLAR
			SPECIFICATION		
			AMPS/PHASE		0.75
			RESISTANCE/PHASE(Ohms)@25°C		6.70±10%
			INDUCTANCE/PHASE(mH)@1KHz		5.80±20%
			MINIMAL THRUST(N)@300 PPS		15
			STEP ANGLE(°)		1.80
STEP ACCURACY(NON-ACCUM)		±5.00%			
PIN NO	BIPOLAR	LEADS	LEAD(mm)		5.08
1	A+	RED	LINEAR TRAVEL/STEP(mm)		0.0254
2	A-	RED/WHT	AMBIENT TEMPERATURE		-10°C~50°C[14°F~122°F]
3	B+	GRN/WHT	INSULATION CLASS		B 130°C[266°F]
4	B-	GRN	TEMPERATURE RISE		MAX.80°C

**OSMTEC**<sup>®</sup>  
Stepper Motor Specialists

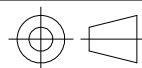

mm			
UNITS	DRN	LDJ	1.15.2026
3:2	APVD	ZPJ	1.20.2026
SCALE	SIGNATURE		DATE

**LINEAR STEPPER MOTOR**

**11N18S0754HD3-250RS**